

### **Tips on Using:**

The following guide provides helpful information for glue gun HMG-HD3 and hot melts adhesives.

HMG-HD3 6/06

1. The normal working time of the hot-melt is thirty (30) seconds. After the adhesive has been extruded onto the bonding surface, the part should be pressed together within fifteen to twenty (15-20) seconds. The bond will have about 90% of its bond strength in one minute.
2. The working time of the hot-melt can be extended to fifty to sixty (50-60) seconds by applying the adhesive in large drops (11mm diameter) or shortened to less than ten (10) seconds by extruding the adhesive in a thin line.
3. Large areas are difficult to bond because the adhesive will harden before you have extruded the required amount.
4. Preheating the bonding surface to slightly above room temperature will improve the bonding strength. Direct sunlight will improve this. This action is particularly important when gluing metal pieces.
5. The hot-melt adheres well to porous surfaces like paper, cloth, particleboard, and pinewood.
6. The hot-melt adhesives quick set time eliminates the need for clamps or other holding devices.
7. The hot-melt begins to soften when the temperature exceeds 150°F and should not be used for items that will be subjected to temperatures above that.
8. Hot-melt adhesives can be used in place of nails, staples, tapes, or liquid glue: however, they should not be used to replace structural fastener where heavy loads are involved.
9. If the glue is stringing from the nozzle you may want to swirl the nozzle in a circular motion, the heat of the nozzle will cut the string. If the glue string lands on your project, allow the glue to dry, then take a hair dryer and blow off the glue string. Increasing the temperature will also help eliminate stringing, also known as “angel hair”.

### **Operation:**

1. Plug the glue gun into a 115v outlet; red light on means the power is on.
2. Allow the tool to heat for approximately 3-5 minutes. Insert a stick of adhesive (11mm or ½”) diameter into the back of the tool.
3. When the gun is fully heated, squeeze the trigger slowly, until the melted material begins to flow from the nozzle. Release the trigger to stop the glue flow.
4. The output volume of the glue can be adjusted by adjusting the stroke adjustor screw.
5. Different nozzle tips are available for different gluing applications and output amount.

### **Save these safety rules for future use:**

1. It is normal for this tool to become quite warm during use. This is normal and does not indicate a problem.
2. The glue gun should be unplugged after use or if it will not be used within 2-hour period. The adhesive can be stored indefinitely in the unheated gun and re-melted by heating up the tool.
3. If you accidentally touch the molten hot glue, immediately immerse the affected area in cold water and call a doctor. The injured area should be attended by a medical professional.
4. Some materials are heat-sensitive and can be damaged by the hot nozzle or even the hot glue. Whenever possible, test a piece of scrap material or a hidden portion of the object being repaired.



## ***Operating Instructions***

***Heavy Duty***  
**Hot Melt Glue Gun**  
**Model: HMG-HD3**  
**Specification: 120 VAC 300W**  
**Glue stick size: ½” or 11~ 12 mm**

**The Gluefast Company, Inc.**  
**Neptune, NJ 07753**  
**[www.gluefast.com](http://www.gluefast.com)**

**READ SAFETY RULES AND INSTRUCTIONS CAREFULLY!**

## WARNING:

1. When using this hot melt glue gun, always follow basic safety precautions. This will reduce the possibility of accidental injury due to burns or electrical shock.
2. Always wear safety glasses and protective gloves and clothing. Long sleeve shirts and pants.

## Read all Safety Instructions:

- **Work area.** This tool is designed to be used on a clean, dry work surface. Excessive dust and dirt may reduce the lifetime of this tool. Do not use in wet or damp locations. Your work areas should keep well lit.
- **This tool is recommended for indoor use only.** Do not use outdoors.
- **Keep children away.** Small children should be kept away from work area. Accidental contact with tool or extension cord should be avoided.
- **Glue gun storage.** After use, allow glue gun to cool completely prior to storage. When not in use, the glue gun should be stored in dry and secure location out of the reach of children.
- **Electrical cord precautions.** Do not carry the tool by the cord or yank to disconnect from the receptacle. Keep the cord away from the nozzle or other high heat sources. Periodically inspect the electrical cord for any sign of wear or damage.
- **Disconnect electrical power.** When not in use, before servicing, and when changing. Do not yank on cord to unplug from electrical receptacle.
- **Stay alert.** Pay attention to your work. Beware of any dripping hot glue from your project. Use common sense. Do not operate this gun when you are tired. Do not operate under the influence of alcohol or other drugs that may impair your physical abilities.
- **Do not touch the heated nozzle of the glue gun or the hot adhesive.** The operating temperature of this tool is 446°F (230°C).
- **Use recommended accessories.** Use only recommended adhesives in this glue gun. Putting other materials than recommended may result in accidental injury and permanent damage to the glue gun. For example: do not attempt to melt crayons or candles.
- **Never use the tool if it is damaged in any way. Hot melt adhesives are not a replacement for structural fastener.**
- **Hot melt glue should not be used for projects that will be exposed to extreme heat.** Some adhesive used with this glue gun can soften at about 150°F.
- **Do not attempt to remove unused portion of a glue stick from the tool.**
- Do not expose the glue gun to extreme changes in temperature during or directly after use. Never immerse glue gun in water or other liquids to speed cooling process. Allow the gun to air cool only.
- Children should not use this glue gun.
- Do not leave the glue gun unattended while plugged in or in a hot condition.
- Make sure to have sufficient eye protective wear, like full mask, in order to avoid damaging materials entering and causing long lasting effect to eye area, during use.

## Preventive Maintenance

1. To prevent the clogging of the glue gun, keep feeding mechanism and melt chamber free from dirt and other foreign debris. Store unused glue sticks in a clean environment.
2. Do not pull glue stick from the back of the glue gun. The feed mechanism may be damaged or impaired. If you desire to change types of glue, cut off the protruding end and feed the remainder through with the new type of glue.
3. Do not lay heated gun on its side. Keep the heated gun in an upright position, on the metal stand or workbench, with nozzle pointed down.
4. If melted glue has escaped from the melt chamber entrance and is interfering with the feed mechanism; allow gun to cool, and gently remove the obstructing glue.

5. Replace the nozzle if glue drips excessively. Do not attempt to change nozzle when glue is cold. To change, the gun must be heated until the glue is softened enough to remove nozzle (about 1 minute). Use gloves and with a wrench, remove the old nozzle. Flush glue through the gun, to clean out the melting chamber. Replace with a new nozzle. Tighten only until snug. Do not over tighten.
6. Keep outside of glue gun clean.

## HMG-HD3 Special features:

- 300 watts for greater glue output than other glue guns
- Non breakable handles and light weight
- Unique effort-saving trigger, with circular TPR handle for comfortable long hour operation

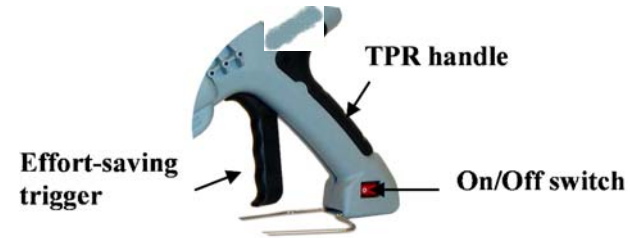

- Adjustable temperature design: work with the right temperature for the required glue properties. Temperature is adjustable between 248°F-446°F (120°C-230°C).

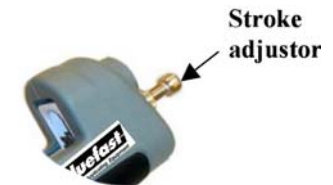
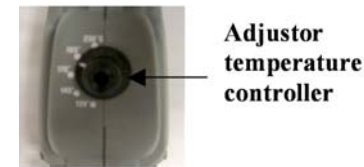

- Stroke adjustor: Each piece comes with a stroke adjustor, and allows user to pre-set the amount of glue output correctly.

## Glue Gun HMG-HD3 Schematic Diagram

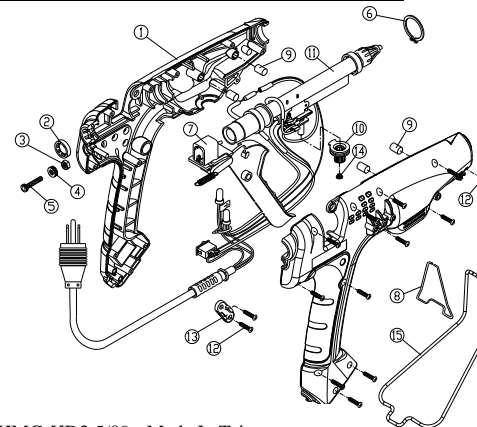

No.	Name	Part No.	Qty
1	Handle sets	2653010P	1
2	O-ring	2114032-G	1
3	Nut	9003039	1
4	Stroke adjustor nut	2527020	1
5	Stroke adjustor screw	9003052-032	1
6	Snap ring C	9004006-S23	1
7	Trigger set	2553041	1
8	Stand	2612041	1
9	Locating post	2333030	4
10	Temp. Adjustor	2553141-B	1
11	Heater set	2650520	1
12	Screw	9003003	14
13	Cord fixer	2613030	1
14	Temp. Adjustor cap	2553142-B	1
15	Supporting stand	2612040	1